



24VDC

EVA.7



CONTROL UNITS:

EVA.7 ——— CP.EVA

179



ROAD BARRIERS

control unit with integrated receiver and absolute encoder
 built-in battery charger
 external release
 2 standard 480 mm springs included

**for passages up to 7 m**

24 Vdc | intensive use

- 24 Vdc electromechanical barrier for intensive use with control unit with integrated receiver, battery charger and extended range switching power supply from 100 to 250 Vac
- Integrated absolute encoder, which ensures greater precision in slowdowns and advanced control of the boom movement so that it never loses the reference position of the boom even if there is a power cut or the automatic device is released
- Integrated STC System for precise torque calculation
- Easy installation and possibility of quick connection for operation of opposed barriers, thanks to the SIS accessory board
- LED.AL8 arm lights with adjustable intensity
- Reduced energy use on stand-by
- Possibility to install FTC.S photocells using concealed system so that they are perfectly integrated
- Integrated flashing lamp (requires EVA.LAMP accessory)
- Available in right or left side versions

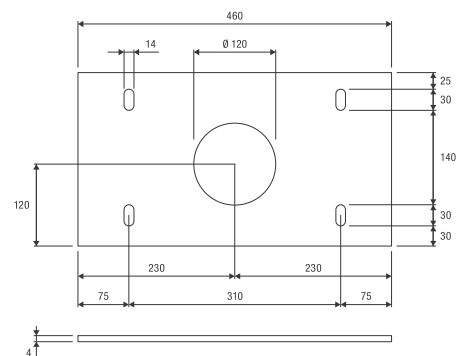
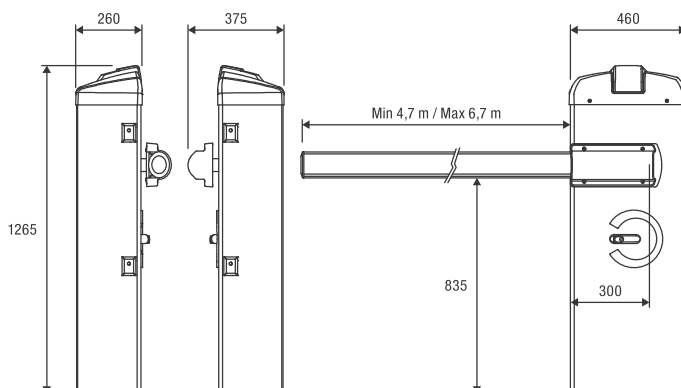
Foundation plate not included (VE.P650)

VE.P650



EVA7.A
Painted elliptical aluminium arm complete with cap, profile in shock-proof rubber (L= 7 m).

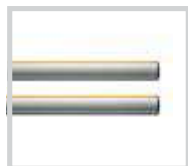

EVA7.A2
Painted elliptical aluminium arm cut into two pieces measuring 3.5 m each. Equipped with joint.



EVA7.G
Aluminium joint.



VE.P650
Foundation plate with coach screws.



VE.AM
Mobile support for arms.

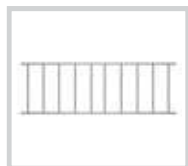

VE.RAST
Aluminium rack L= 2 m. H= 60 cm



EVA.AF
Painted fixed support.



LED.AL8
Set of LED lights for arm. L = 8 m.



EVA.LAMP
Circuit for flashing light.



VE.CS
Traffic-light control unit for LED.TL.



LED.TL
2 light 230 Vac LED traffic light.



EVA.KM
364 mm spring.



SIS
Quick connection electronic board that allows synchronised movement of 2 automation devices (opposed barriers). One board for each motor is necessary.



LSR.B
Laser control and safety sensor for barriers, certified EN12453 type E. Adjustable Detection area up to 9.9 m x 9.9 m.



VE.KM1HN
Single-channel 24 Vac/dc detector for magnetic loop.
VE.KM2HN
Two-channel 24 Vac/dc detector for magnetic loop.



CABLE.L6
Loop with 6 m connection cable, for VE.KM1HN/VE.KM2HN.
CABLE.L10
Loop with 10 m connection cable, for VE.KM1HN/VE.KM2HN.



FTC.S
24 Vac/dc surface mounting photocell. It is possible to synchronise up to 4 pairs of photocells.



CAT.29
Set of 20 adhesive refractor strips.

□ **WITHOUT ACCESSORIES**

BAR LENGTH (m)	TYPE OF SPRING	APPROX TENSIONING OF THE SPRING (mm)	
		EVA.KM	STANDARD SPRING
5	STANDARD SPRING	---	35
5,5	STANDARD SPRING	---	90
6	EVA.KM + STANDARD SPRING	31	15
6,5	N° 2 STANDARD SPRINGS	---	5 / 5
7	N° 2 STANDARD SPRINGS	---	35 / 35

□ **WITH ACCESSORIES:** CAP, EVA.L, SC.RES/VE.RAST, VE.AM

BAR LENGTH (m)	TYPE OF SPRING	APPROX TENSIONING OF THE SPRING (mm)	
		EVA.KM	STANDARD SPRING
5	STANDARD SPRING	---	100
5,5	EVA.KM + STANDARD SPRING	52	138
6	N° 2 STANDARD SPRINGS	---	20 / 20
6,5	N° 2 STANDARD SPRINGS	---	65 / 65
7	---	---	--- / ---

Attention: The installation of the VE.RAST interferes with the use of the SC.RES and vice versa. The installation of the LED.AL8 lights kit does not influence the balancing of the bar.

TECHNICAL DATA	EVA.7
Power supply	100 ÷ 250 Vac (50-60Hz)
Motor supply	24 Vdc
Max absorbed current	3.1 / 1.6 A
Torque	285 Nm
Opening time	3.5" ÷ 6"
Duty cycle	intensive use
Protection level	IP44
Operating temperature	-20°C / +50°C
Weight	78.4 kg
Items no. per pallet	6