

230_{VAC}

BULL8M

BULL8 OM

RESIDENTIAL | COMMERCIAL USE

control unit with built-in receiver and encoder
personalised release key
BULL8OM: oil lubrication

fino a 800 kg



CONTROL UNITS:

BULL8M	CP.BULL8-OM	156
BULL8M.S	CP.BULL8-OM	156
BULL8 OM	CP.BULL8-OM	156
BULL8 OM.S	CP.BULL8-OM	156







230 Vac

- 230 Vac gear motor with integrated control unit and encoder
- The encoder device ensures crush prevention and precision in the gate moving phases
- Full metal mechanics and oil lubrication ensure maximum gear durability. The type of oil used is also particularly effective, and ensures maximum efficiency even at low temperatures
- Version with magnetic limit switches available (BULL8M.S, BULL8OM.S)

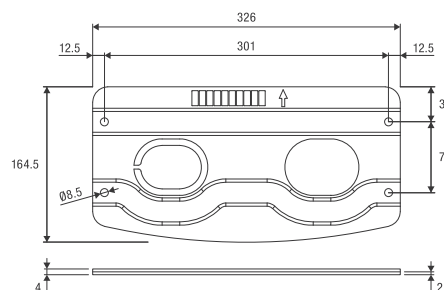
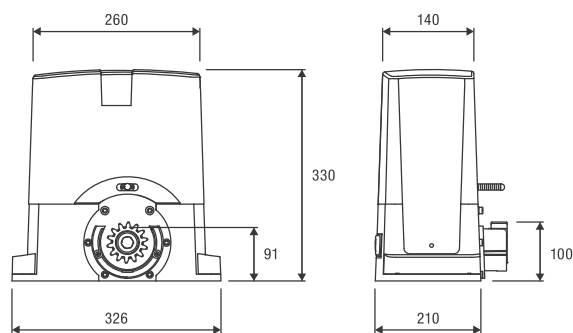

Reinforced foundation plate Dima included.
Dimensions 326x164.5x2 mm, motor fixing distance 301x75 mm, 4 holes Ø 8.5 mm.



COMPLETE KITS	 MOTOR	 PHOTOCELLS	 FLASHING LIGHT	 TRANSMITTER
KBULL8M	1x BULL8M	1x PUPILLA.T	1x LAMPY	1x TO.GO2VA
KBULL8OM	1x BULL8 OM	1x PUPILLA.T	1x LAMPY	1x TO.GO2VA



RI.M4F
M4 rack, to weld or attach with screws, 30x12x1000 mm slotted and galvanised. Supplied with M6 screws and threaded spacers.



RI.M4F2
M4 rack, to weld or attach with screws, 30x12x2000 mm slotted and galvanised. Supplied with M6 screws and threaded spacers.



RI.M4Z
M4 galvanised rack to weld 22x22x2000 mm.



RI.M4ZF
Galvanised slotted M4 rack 22x22x2010 mm for fastening to the side with the teeth. Supplied with M6 screws.



RI.M4P
Nylon rack with steel core, to attach with screws, M4, 28x40x1000 mm. Slotted, provided with self-drilling screws.



BULL.P-1
Raised foundation plate. Height 34 mm. Floor fixing distance 353x117 mm, no. 4 Ø 11 mm. External dimensions 372x167 mm.



BULL.P3
Raised foundation plate. Height 34 mm. Floor fixing distance 260x117 mm, no. 4 Ø 11 mm. External dimensions 326x167 mm.



SB.BULL8.F
Externally fitted anti-intrusion cable unlock device (L=4.5m).

TECHNICAL DATA	BULL8M*	BULL8M.S*	BULL8 OM*	BULL8 OM.S*
Power supply	230 Vac (50-60Hz)	230 Vac (50-60Hz)	230 Vac (50-60Hz)	230 Vac (50-60Hz)
Motor supply	230 Vac	230 Vac	230 Vac	230 Vac
Max absorbed current	2.6 A	2.6 A	2.6 A	2.6 A
Max Thrust	940 N	940 N	940 N	940 N
Opening speed	10.5 m/min	10.5 m/min	10.5 m/min	10.5 m/min
Duty cycle	30%	30%	40%	40%
Protection level	IP44	IP44	IP44	IP44
Magnetic limit switches	NO	YES	NO	YES
Operating temperature	-20°C /+50°C	-20°C /+50°C	-20°C /+50°C	-20°C /+50°C
Lubrication	GREASE	GREASE	OIL	OIL
Max gate weight	800 kg	800 kg	800 kg	800 kg
Driving gear for rack	M4 Z18	M4 Z18	M4 Z18	M4 Z18
Weight	13.6 kg	13.7 kg	14.6 kg	14.7 kg
Items no. per pallet	40	40	40	40
Kit weight	14.5 kg	---	15.4 kg	---
Kits no. per pallet	40	---	40	---

* Available in 115 VAC version